

# MATRIX

## HORIZONTAL MULTISTAGE CENTRIFUGAL ELECTRIC PUMPS

in AISI 304



### PERFORMANCE RANGE (according to ISO 9906 Attachment A)

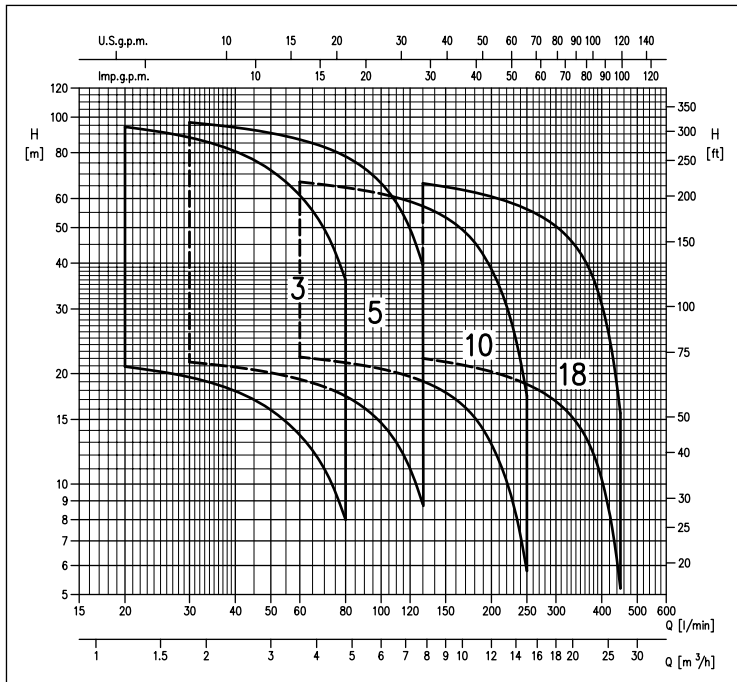

### IDENTIFICATION CODE

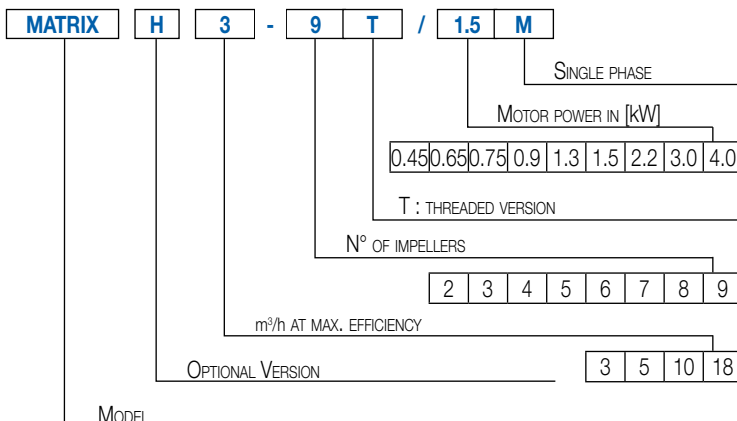

Horizontal multistage centrifugal electric pumps in AISI 304 stainless steel.

### APPLICATIONS

- Industrial washing
- Pressure boosting units
- Industrial plants
- Distribution and treatment of water
- Heating and air conditioning
- Cooling and chiller
- Irrigation
- Recovery of rain water

### TECHNICAL DETAILS

- Sturdy and compact structure
- Available in various versions and models
- WRAS approval for the standard version (up to +85° C) and DM174 (up to +110° C)

### PUMP TECHNICAL DATA

- Temperature of the liquid:
  - from -15° to +85° C (standard)
  - from -15° to +110° C (for TE version for high temperature)
- Maximum working pressure: 10 bar
- Maximum chlorine content: 500 ppm
- Suction connection
  - G1 for MATRIX 3, G1¼ for MATRIX 5,
  - G1½ for MATRIX 10, G2 for MATRIX 18
- Discharge connection
  - G1 for MATRIX 3-5, G1¼ for MATRIX 10,
  - G1½ for MATRIX 18

### MOTOR TECHNICAL DATA

- IE3 high energy-efficiency motors starting from 0.75kW
- Self-ventilated 2 pole asynchronous motor
- Class of insulation F
- IP55 protection degree
- 230V ±10% 50Hz single phase voltage,
- 230/400V ±10% 50Hz three phase voltage
- Permanent capacitor inserted and thermo-amperometric protection with automatic rearm incorporated for the single phase motor
- Protection under user's responsibility for the three phase version

### MATERIALS

- Pump casing, impellers, intermediate stages, seal housing disc and shaft (part in contact with the liquid) in EN 1.4301 (AISI 304)
- Mechanical seal in:
  - Ceramic/Carbon/EPDM (standard)
  - special versions: see p. 43
- Bracket in EN AB-AISI11Cu2(Fe) (microcasted aluminium)

### ACCESSORIES (On request)

- Insulation casing for MATRIX pump casing for applications with refrigerant liquids or liquids with high thermal difference that may generate condensate
- Electric panels
- Vessels
- Floats
- Pressure switches
- Presscomfort - Pressure regulator
- E-power - Variable speed control system
- E-drive - Variable speed control system





# MATRIX

## HORIZONTAL MULTISTAGE CENTRIFUGAL ELECTRIC PUMPS

in AISI 304

### PERFORMANCE CURVES series MATRIX 3 (from 2 to 5 impellers)

(according to ISO 9906 Attachment A)

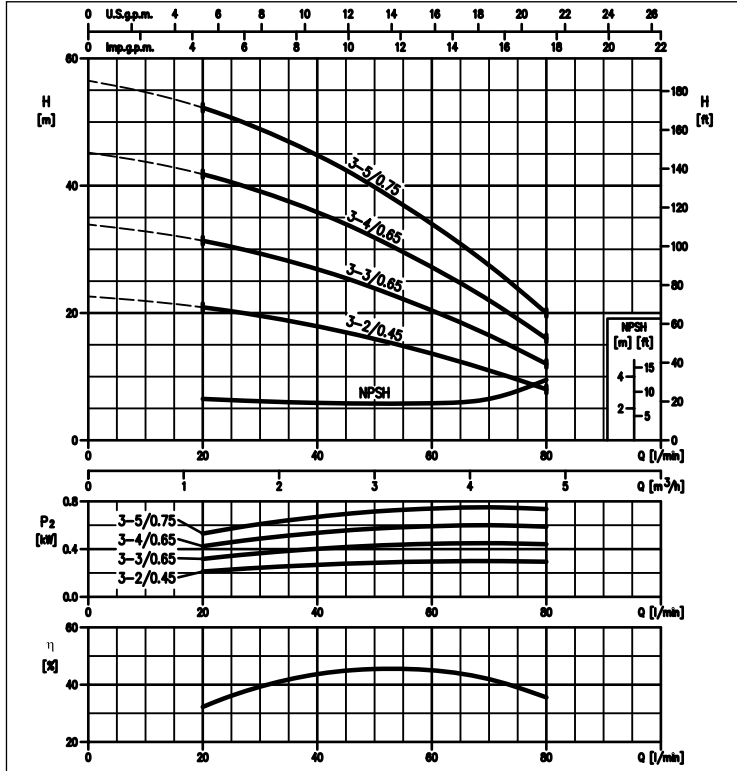

### PERFORMANCE CURVES series MATRIX 3 (from 6 to 9 impellers)

(according to ISO 9906 Attachment A)

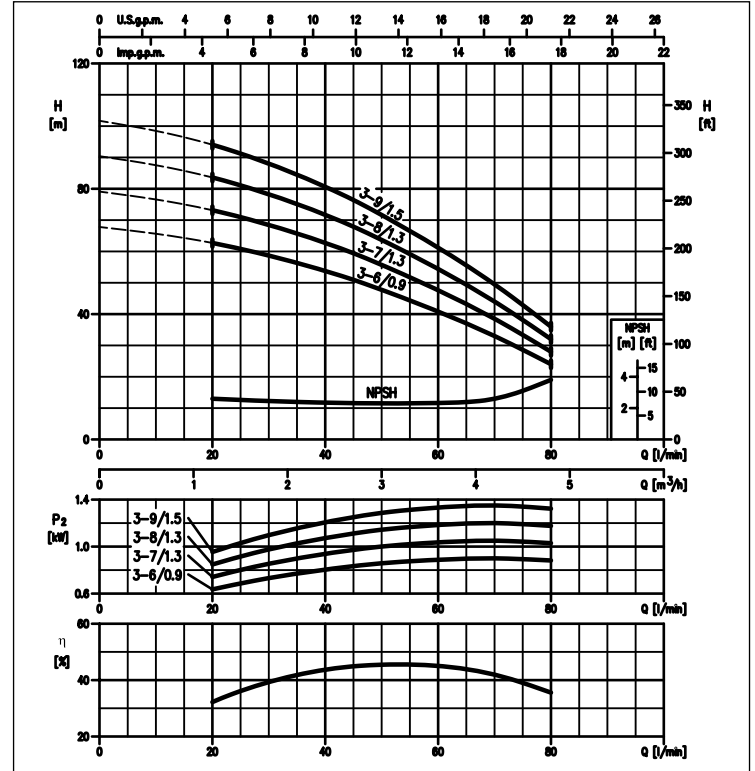

### PERFORMANCE CURVES series MATRIX 5 (from 2 to 5 impellers)

(according to ISO 9906 Attachment A)

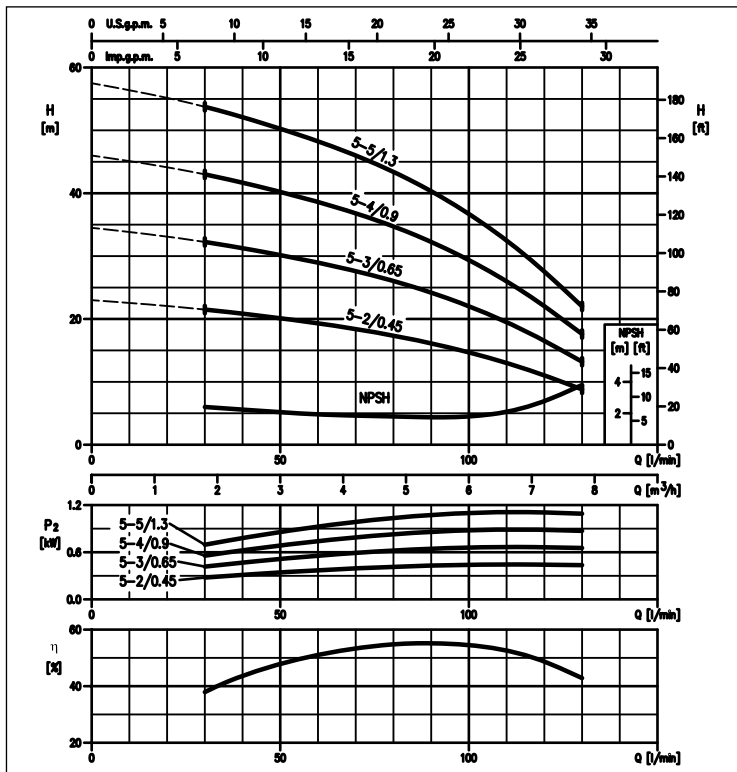

### PERFORMANCE CURVES series MATRIX 5 (from 6 to 9 impellers)

(according to ISO 9906 Attachment A)

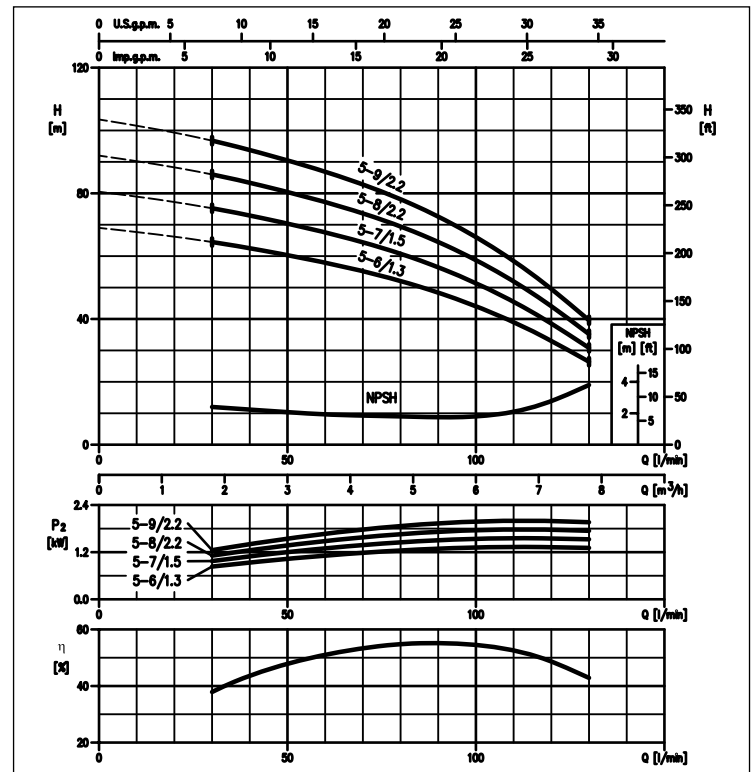

The content of this publication should not be considered mandatory. EBARA Pumps Europe S.p.A. reserves the right to change the content without prior notice.



# MATRIX

## HORIZONTAL MULTISTAGE CENTRIFUGAL ELECTRIC PUMPS

in AISI 304

### PERFORMANCE CURVES series MATRIX 10 (from 2 to 4 impellers)

(according to ISO 9906 Attachment A)

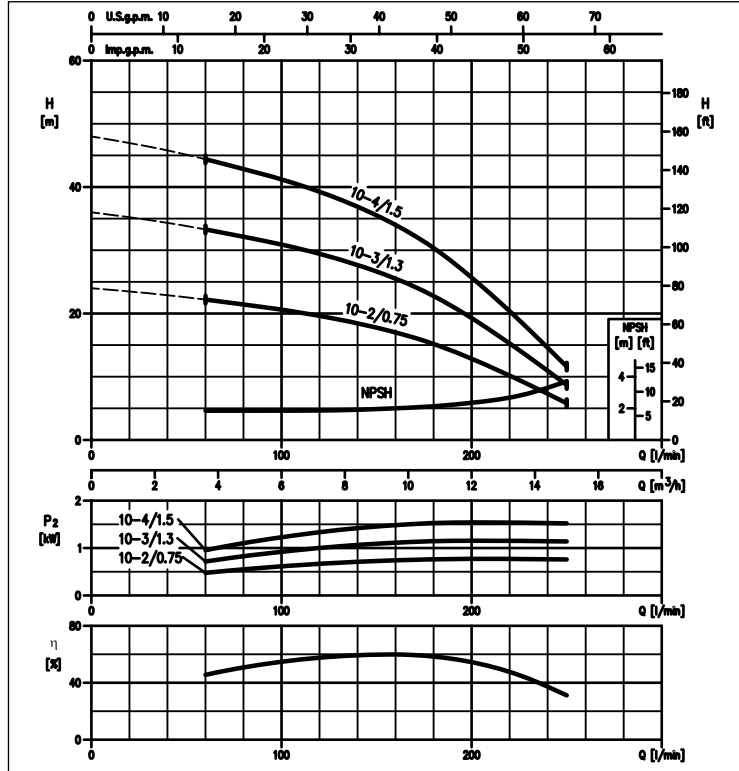

### PERFORMANCE CURVES series MATRIX 10 (from 5 to 6 impellers)

(according to ISO 9906 Attachment A)

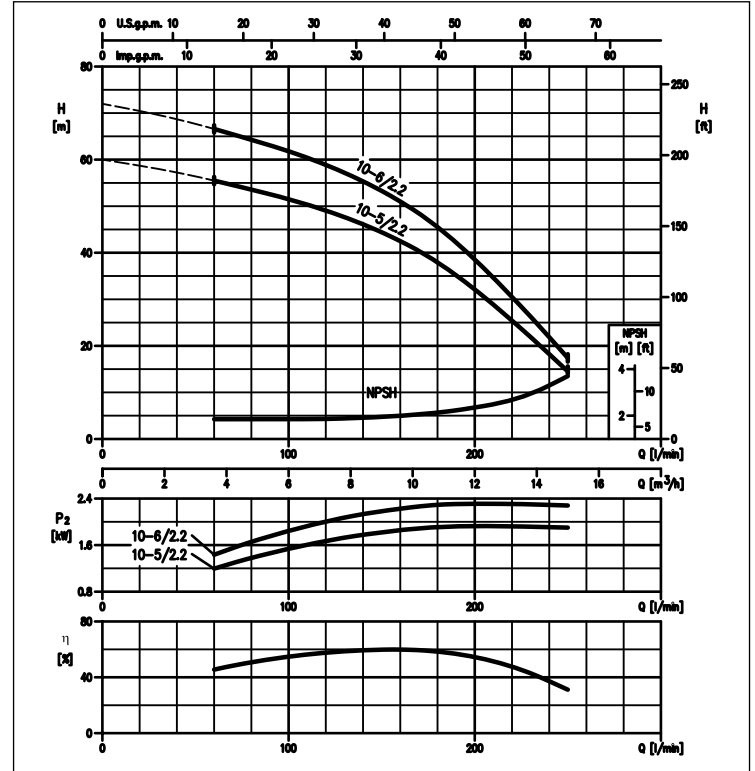

### PERFORMANCE CURVES series MATRIX 18 (from 2 to 4 impellers)

(according to ISO 9906 Attachment A)

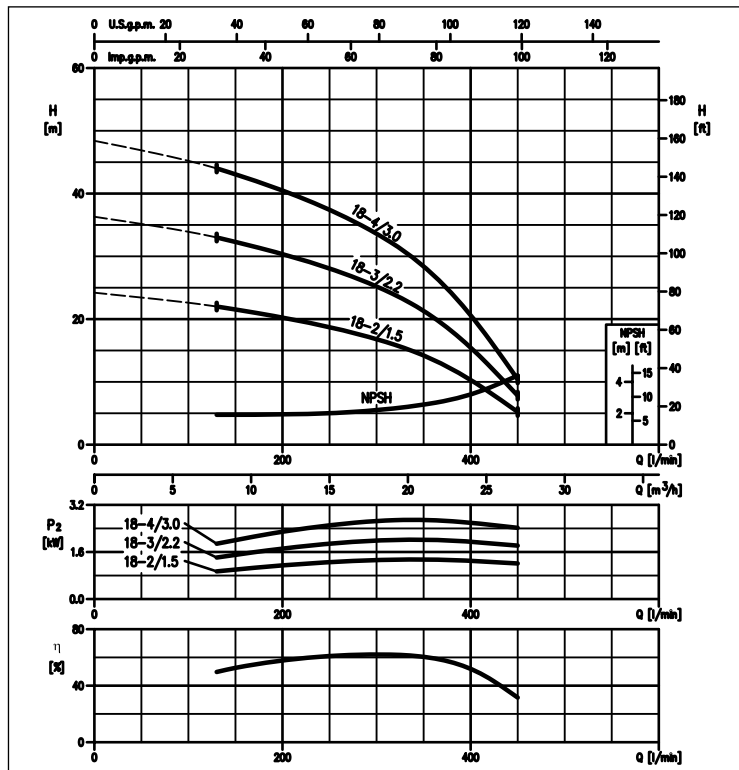

### PERFORMANCE CURVES series MATRIX 18 (5 and 6 impellers)

(according to ISO 9906 Attachment A)

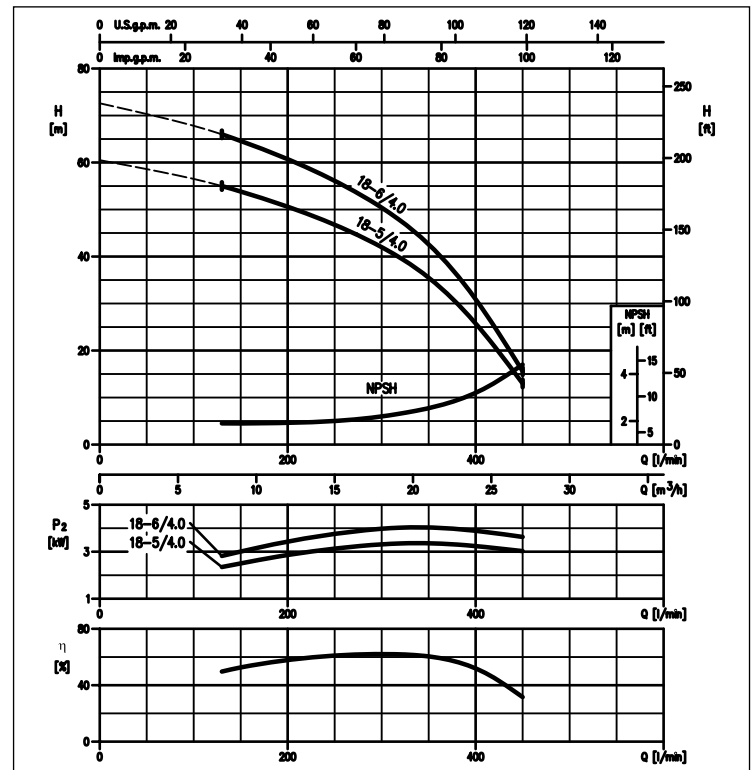

The content of this publication should not be considered mandatory. EBARA Pumps Europe S.p.A. reserves the right to change the content without prior notice.

# MATRIX

## HORIZONTAL MULTISTAGE CENTRIFUGAL ELECTRIC PUMPS

in AISI 304

### PERFORMANCE CHART

Single phase 230V	Model Three phase 230/400V	P <sub>2</sub>		Q = Flow Rate															
		[HP]	[kW]	l/min 20	30	45	60	80	100	130	160	200	250	300	350	400	450		
				m <sup>3</sup> /h 1.2	1.8	2.7	3.6	4.8	6	7.8	9.6	12	15	18	21	24	27		
				H=Head [m]															
MATRIX 3-2T/0.45M	MATRIX 3-2T/0.45	0.6	0.45	20.9	19.6	17.0	13.6	8.0	-	-	-	-	-	-	-	-	-	-	
MATRIX 3-3T/0.65M	MATRIX 3-3T/0.65	0.9	0.65	31.4	29.3	25.5	20.4	12.0	-	-	-	-	-	-	-	-	-	-	
MATRIX 3-4T/0.65M	MATRIX 3-4T/0.65	0.9	0.65	42.0	39.1	34.0	27.2	16.0	-	-	-	-	-	-	-	-	-	-	
MATRIX 3-5T/0.75M	MATRIX 3-5T/0.75	1	0.75	52.5	49.0	42.5	34.0	20.0	-	-	-	-	-	-	-	-	-	-	
MATRIX 3-6T/0.9M	MATRIX 3-6T/0.9	1.2	0.9	62.5	58.5	51.0	41.0	24.0	-	-	-	-	-	-	-	-	-	-	
MATRIX 3-7T/1.3M	MATRIX 3-7T/1.3	1.8	1.3	73.0	68.5	59.5	47.5	28.0	-	-	-	-	-	-	-	-	-	-	
MATRIX 3-8T/1.3M	MATRIX 3-8T/1.3	1.8	1.3	83.5	78.0	68.0	54.5	32.0	-	-	-	-	-	-	-	-	-	-	
MATRIX 3-9T/1.5M	MATRIX 3-9T/1.5	2	1.5	94.0	88.0	76.5	61.0	36.0	-	-	-	-	-	-	-	-	-	-	
MATRIX 5-2T/0.45M	MATRIX 5-2T/0.45	0.6	0.45	-	21.5	20.5	19.3	17.4	14.7	8.8	-	-	-	-	-	-	-	-	
MATRIX 5-3T/0.65M	MATRIX 5-3T/0.65	0.9	0.65	-	32.3	30.7	29.0	26.0	22.0	13.2	-	-	-	-	-	-	-	-	
MATRIX 5-4T/0.9 M	MATRIX 5-4T/0.9	1.2	0.9	-	43.0	41.0	38.6	34.7	29.4	17.6	-	-	-	-	-	-	-	-	
MATRIX 5-5T/1.3M	MATRIX 5-5T/1.3	1.8	1.3	-	54.0	51.0	48.5	43.5	36.7	22.0	-	-	-	-	-	-	-	-	
MATRIX 5-6T/1.3M	MATRIX 5-6T/1.3	1.8	1.3	-	64.5	61.5	58.0	52.0	44.0	26.4	-	-	-	-	-	-	-	-	
MATRIX 5-7T/1.5 M	MATRIX 5-7T/1.5	2	1.5	-	75.5	72.0	67.5	61.0	51.5	30.8	-	-	-	-	-	-	-	-	
MATRIX 5-8T/2.2 M	MATRIX 5-8T/2.2	3	2.2	-	86.0	82.0	77.0	69.5	58.5	35.2	-	-	-	-	-	-	-	-	
MATRIX 5-9T/2.2 M	MATRIX 5-9T/2.2	3	2.2	-	97.0	92.0	87.0	78.0	66.0	39.6	-	-	-	-	-	-	-	-	
MATRIX 10-2T/0.75M	MATRIX 10-2T/0.75	1	0.75	-	-	-	22.2	21.4	20.6	19.1	17.0	12.8	5.8	-	-	-	-	-	
MATRIX 10-3T/1.3M	MATRIX 10-3T/1.3	1.8	1.3	-	-	-	33.3	32.1	30.9	28.6	25.5	19.3	8.7	-	-	-	-	-	
MATRIX 10-4T/1.5M	MATRIX 10-4T/1.5	2	1.5	-	-	-	44.5	43.0	41.0	38.1	34.0	25.7	11.6	-	-	-	-	-	
MATRIX 10-5T/2.2M	MATRIX 10-5T/2.2	3	2.2	-	-	-	55.5	53.5	51.5	47.5	42.5	32.1	14.5	-	-	-	-	-	
MATRIX 10-6T/2.2M	MATRIX 10-6T/2.2	3	2.2	-	-	-	66.5	64.5	62.0	57.0	51.0	38.5	17.4	-	-	-	-	-	
MATRIX 18-2T/1.5M	MATRIX 18-2T/1.5	2	1.5	-	-	-	-	-	-	22.0	21.3	20.2	18.7	16.8	14.2	10.3	5.2	-	
MATRIX 18-3T/2.2M	MATRIX 18-3T/2.2	3	2.2	-	-	-	-	-	-	33.0	31.9	30.4	28.1	25.2	21.3	15.5	7.8	-	
-	MATRIX 18-4T/3	4	3	-	-	-	-	-	-	44.0	42.5	40.5	37.4	33.6	28.4	20.6	10.4	-	
-	MATRIX 18-5T/4	5.5	4	-	-	-	-	-	-	55.0	53.0	50.5	47.0	42.0	35.5	25.8	13.0	-	
-	MATRIX 18-6T/4	5.5	4	-	-	-	-	-	-	66.0	64.0	60.5	56.0	50.5	42.5	30.9	15.6	-	

### DIMENSIONS

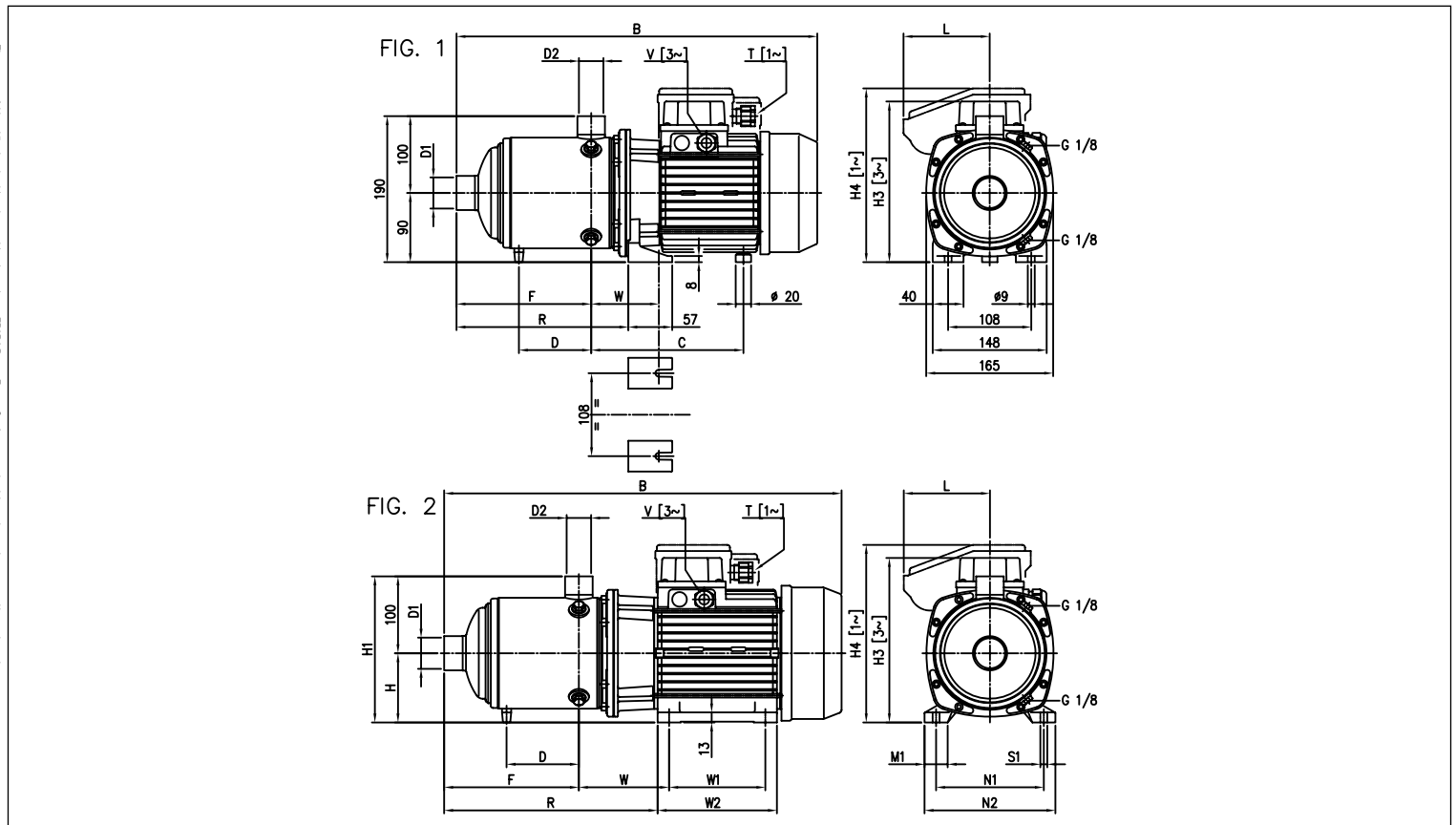

The content of this publication should not be considered mandatory. EBARA Pumps Europe S.p.A. reserves the right to change the content without prior notice.

# MATRIX

## HORIZONTAL MULTISTAGE CENTRIFUGAL ELECTRIC PUMPS

in AISI 304

**MATRIX 3 DIMENSIONS TABLE**

Modello	Fig.	Dimensioni [mm]															Peso [kg]	
		B	C	D	F	H3 [1]	H4 [2]	L	R	T [2]	V [1]	W	D1	D2	*	*		
MATRIX 3-2T/0.45M	1	360	-	171	-	103	-	200	86,5	151,5	PG11	-	-	88÷97	1"	1"	8,5	-
MATRIX 3-2T/0.45	1	360	-	171	-	103	192	-	-	151,5	-	PG11	-	88÷97	1"	1"	8,4	-
MATRIX 3-3T/0.65M	1	360	-	171	-	103	-	200	86,5	151,5	PG11	-	-	88÷97	1"	1"	9,9	-
MATRIX 3-3T/0.65	1	360	-	171	-	103	192	-	-	151,5	-	PG11	-	88÷97	1"	1"	9,8	-
MATRIX 3-4T/0.65M	1	384	-	171	-	127	-	200	86,5	175,5	PG11	-	-	88÷97	1"	1"	10,6	-
MATRIX 3-4T/0.65	1	384	-	171	-	127	192	-	-	175,5	-	PG11	-	88÷97	1"	1"	10,4	-
MATRIX 3-5T/0.75M	1	408	-	171	-	151	-	200	86,5	199,5	PG11	-	-	88÷97	1"	1"	12,5	-
MATRIX 3-5T/0.75	1	408	408	171	-	151	192	-	-	199,5	-	PG11	M16x1.5	88÷97	1"	1"	12,4	12,4
MATRIX 3-6T/0.9M	1	432	-	171	-	175	-	219	106	223,5	M20x1,5	-	-	88÷97	1"	1"	13,7	-
MATRIX 3-6T/0.9	1	444	444	171	-	175	192	-	-	223,5	-	PG11	M16x1.5	88÷97	1"	1"	13,6	13,6
MATRIX 3-7T/1.3M	1	493	-	198	110,5	199	-	226	112	247,5	M20x1,5	-	-	88÷97	1"	1"	16,3	-
MATRIX 3-7T/1.3	1	493	518	198	110,5	199	209	-	-	247,5	-	PG11	M20x1.5	88÷97	1"	1"	17,0	17,9
MATRIX 3-8T/1.3M	1	517	-	198	134,5	223	-	226	112	271,5	M20x1,5	-	-	88÷97	1"	1"	16,3	-
MATRIX 3-8T/1.3	1	517	542	198	134,5	223	209	-	-	271,5	-	PG11	M20x1.5	88÷97	1"	1"	17,8	18,7
MATRIX 3-9T/1.5M	1	541	-	198	158,5	247	-	226	112	295,5	M20x1,5	-	-	88÷97	1"	1"	18,3	-
MATRIX 3-9T/1.5	1	554	566,5	198	158,5	247	209	-	-	295,5	-	PG11	M20x1.5	88÷97	1"	1"	20,0	20,9

[1]= Three-phase only

[2]= Single phase only

**MATRIX 5-10-18 DIMENSIONS TABLE**

Modello	Fig.	Dimensioni [mm]																				Peso [kg]		
		B	C	D	F	H	H1	H3 [1]	H4 [2]	L	R	T [2]	V [1]	W	W1	W2	M1	N1	N2	S1	D1		D2	
MATRIX 5-2T/0.45 M	1	360	171	-	103	-	-	-	200	86,5	151,5	PG11	-	88÷97	-	-	-	-	-	-	-	1 1/4	1"	8,5
MATRIX 5-2T/0.45	1	360	171	-	103	-	-	192	-	-	151,5	-	PG11	88÷97	-	-	-	-	-	-	-	1 1/4	1"	8,4
MATRIX 5-3T/0.65 M	1	360	171	-	103	-	-	-	200	86,5	151,5	PG11	-	88÷97	-	-	-	-	-	-	-	1 1/4	1"	9,9
MATRIX 5-3T/0.65	1	360	171	-	103	-	-	192	-	-	151,5	-	PG11	88÷97	-	-	-	-	-	-	-	1 1/4	1"	9,8
MATRIX 5-4T/0.9 M	1	384	171	-	127	-	-	-	219	106	175,5	M20x1,5	-	88÷97	-	-	-	-	-	-	-	1 1/4	1"	12,2
MATRIX 5-4T/0.9	1	396	171	-	127	-	-	192	-	-	175,5	-	M16x1,5	88÷97	-	-	-	-	-	-	-	1 1/4	1"	12,4
MATRIX 5-5T/1.3 M	1	445	198	-	151	-	-	-	226	112	199,5	M20x1,5	-	88÷97	-	-	-	-	-	-	-	1 1/4	1"	15,8
MATRIX 5-5T/1.3	1	470	198	-	151	-	-	209	-	-	199,5	-	M20x1,5	88÷97	-	-	-	-	-	-	-	1 1/4	1"	16,7
MATRIX 5-6T/1.3 M	1	469	198	-	175	-	-	-	226	112	223,5	M20x1,5	-	88÷97	-	-	-	-	-	-	-	1 1/4	1"	15,2
MATRIX 5-6T/1.3	1	494	198	-	175	-	-	209	-	-	223,5	-	M20x1,5	88÷97	-	-	-	-	-	-	-	1 1/4	1"	17,1
MATRIX 5-7T/1.5 M	1	493	198	110,5	199	-	-	-	226	112	247,5	M20x1,5	-	88÷97	-	-	-	-	-	-	-	1 1/4	1"	18,3
MATRIX 5-7T/1.5	1	518,5	198	110,5	199	-	-	209	-	-	247,5	-	M20x1,5	88÷97	-	-	-	-	-	-	-	1 1/4	1"	19,6
MATRIX 5-8T/2.2 M	2	565	-	134,5	223	90	190	-	231	112	325,5	M20x1,5	-	117,5	125	155	30	140	170	9	1 1/4	1"	22,3	
MATRIX 5-8T/2.2	1	542,5	198	134,5	223	-	-	209	-	-	271,5	-	M20x1,5	88÷97	-	-	-	-	-	-	-	1 1/4	1"	19,6
MATRIX 5-9T/2.2 M	2	589	-	158,5	247	90	190	-	231	112	349,5	M20x1,5	-	117,5	125	155	30	140	170	9	1 1/4	1"	23,3	
MATRIX 5-9T/2.2	1	566,5	198	158,5	247	-	-	209	-	-	295,5	-	M20x1,5	88÷97	-	-	-	-	-	-	-	1 1/4	1"	19,7
MATRIX 10-2T/0.75 M	1	379	175	-	118	-	-	-	200	86,5	170,5	PG11	-	92÷101	-	-	-	-	-	-	-	1 1/2	1 1/4	11,3
MATRIX 10-2T/0.75	1	379	175	-	118	-	-	192	-	-	170,5	-	M16x1,5	92÷101	-	-	-	-	-	-	-	1 1/2	1 1/4	11,2
MATRIX 10-3T/1.3 M	1	416	202	-	118	-	-	-	226	112	170,5	M20x1,5	-	92÷101	-	-	-	-	-	-	-	1 1/2	1 1/4	14,3
MATRIX 10-3T/1.3	1	441	202	-	118	-	-	209	-	-	170,5	-	M20x1,5	92÷101	-	-	-	-	-	-	-	1 1/2	1 1/4	14,5
MATRIX 10-4T/1.5 M	1	446	202	-	148	-	-	-	226	112	200,5	M20x1,5	-	92÷101	-	-	-	-	-	-	-	1 1/2	1 1/4	15,6
MATRIX 10-4T/1.5	1	471,5	202	-	148	-	-	209	-	-	200,5	-	M20x1,5	92÷101	-	-	-	-	-	-	-	1 1/2	1 1/4	18,2
MATRIX 10-5T/2.2 M	2	524	-	-	178	90	190	-	231	112	284,5	M20x1,5	-	121,5	125	155	30	140	170	9	1 1/2	1 1/4	21,8	
MATRIX 10-5T/2.2	1	501,5	202	-	178	-	-	209	-	-	230,5	-	M20x1,5	92÷101	-	-	-	-	-	-	-	1 1/2	1 1/4	18,8
MATRIX 10-6T/2.2 M	2	554	-	118,5	208	90	190	-	231	112	314,5	M20x1,5	-	121,5	125	155	30	140	170	9	1 1/2	1 1/4	22,1	
MATRIX 10-6T/2.2	1	531,5	202	118,5	208	-	-	209	-	-	260,5	-	M20x1,5	92÷101	-	-	-	-	-	-	-	1 1/2	1 1/4	19,2
MATRIX 18-2T/1.5M	1	442	205	-	141	-	-	-	226	112	196,5	M20x1,5	-	95÷104	-	-	-	-	-	-	-	2"	1 1/2	14,5
MATRIX 18-2T/1.5M	1	467,5	205	-	141	-	-	209	-	-	196,5	-	M20x1,5	95÷104	-	-	-	-	-	-	-	2"	1 1/2	17,1
MATRIX 18-3T/2.2M	2	490	-	-	141	90	190	-	231	112	250,5	M20x1,5	-	124,5	125	155	30	140	170	9	2"	1 1/2	20,7	
MATRIX 18-3T/2.2	1	467,5	205	-	141	-	-	209	-	-	196,5	-	M20x1,5	95÷104	-	-	-	-	-	-	-	2"	1 1/2	18,1
MATRIX 18-4T/3	2	565	-	-	178,5	90	190	214	-	-	288	-	M20x1,5	124,5	125	155	30	140	170	9	2"	1 1/2	23,8	
MATRIX 18-5T/4	2	615	-	123	216	100	200	241	-	-	315	-	M20x1,5	114	140	170	35	160	192	11	2"	1 1/2	33,2	
MATRIX 18-6T/4	2	652	-	160,5	253,5	100	200	241	-	-	352,5	-	M20x1,5	114	140	170	35	160	192	11	2"	1 1/2	34,2	

[1]= Three-phase only

[2]= Single phase only

The content of this publication should not be considered mandatory. EBARA Pumps Europe S.p.A. reserves the right to change the content without prior notice.

# MATRIX

## HORIZONTAL MULTISTAGE CENTRIFUGAL ELECTRIC PUMPS

in AISI 304

### MATRIX 3-5-10 SECTIONAL VIEW

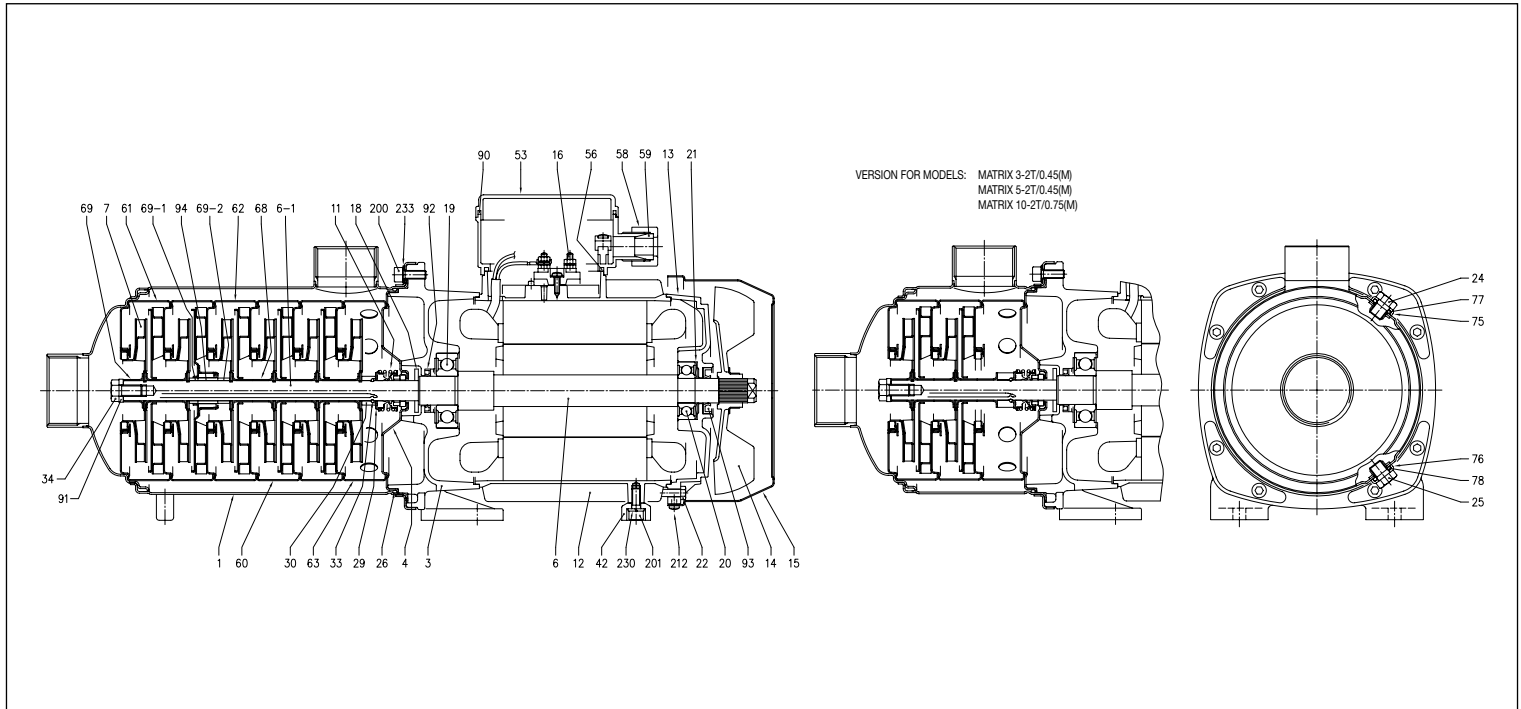

### MATRIX 18 SECTIONAL VIEW

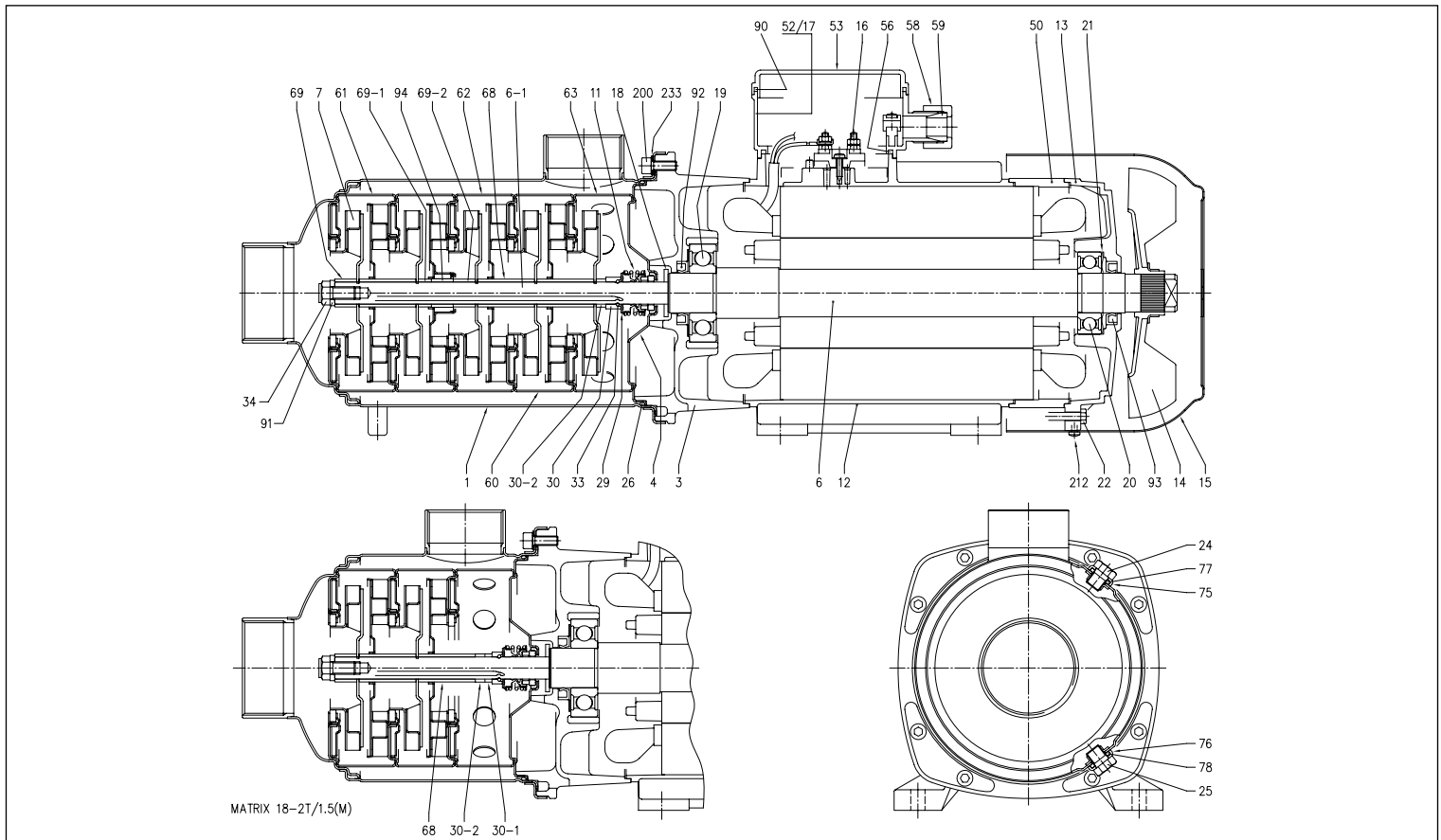

The content of this publication should not be considered mandatory. EBARA Pumps Europe S.p.A. reserves the right to change the content without prior notice.



## HORIZONTAL MULTISTAGE CENTRIFUGAL ELECTRIC PUMPS

in AISI 304

### MATERIALS TABLE

Ref.	Name	Materials	Ref.	Name	Materials
1	Pump casing	EN 1.4301 (AISI 304)	42	Motor support	Aluminium
3	Motor bracket	EN AB-AISI11Cu2(Fe)	50	Motor spacer [2]	Aluminium
4	Casing cover	EN 1.4301 (AISI 304)	52	Capacitor-holder box [1]	ABS
6	Shaft	-	53	Capacitor-holder box cover [1]	ABS
6-1	Pump shaft	EN 1.4301 (AISI 304)	56	Box gasket	NBR
7	Impeller	EN 1.4301 (AISI 304)	58	Nut ring	-
11	Mechanical seal	Ceramic/Carbon/EPDM	59	Conic gasket	NBR
12	Motor frame	-	60	Intermediate stage	EN 1.4301 (AISI 304)+PTFE
13	Motor cover	Aluminium	61	Intermediate stage (suction)	EN 1.4301 (AISI 304)+PTFE
14	Fan	PA	62	Intermediate stage (bearing)	EN 1.4301 (AISI 304) + PTFE + Ceramic
15	Fan cover	Galvanised Fe P04	63	Intermediate stage (discharge)	EN 1.4301 (AISI 304) + PTFE
16	Terminal Box	-	68	Shaft casing (intermediate)	EN 1.4301 (AISI 304)
17	Terminal Box cover	Aluminium	69	Impeller spacer	EN 1.4301 (AISI 304)
18	Splash ring	NBR	69-1	Shaft casing (adapter)	EN 1.4301 (AISI 304)
19	Bearing (pump side)	-	69-2	Shaft casing (adapter)	EN 1.4301 (AISI 304)
20	Bearing (motor side)	-	75	Washer	EN 1.4301 (AISI 304)
21	Adjustment ring	Steel C70	76	Washer	EN 1.4301 (AISI 304)
22	Tie-rod	Galvanised Fe 42	77	O-Ring	EPDM
24	Plug	EN 1.4301 (AISI 304)	78	O-Ring	EPDM
25	Plug	EN 1.4301 (AISI 304)	90	Terminal box cover [1]	NBR
26	O-Ring	EPDM	91	Shaft washer	EN 1.4301 (AISI 304)
29	Washer	EN 1.4301 (AISI 304)	92	Seal ring	-
30	Holding ring	EN 1.4301 (AISI 304)	93	Seal ring	-
30-1-2	Shaft casing	EN 1.4301 (AISI 304)	94	Guide bush	WC - Tungsten carbide
33	Ring	EN 1.4301 (AISI 304)	200	Screw (pump body)	EN 1.4301 (AISI 304)
34	Screw	EN 1.4301 (AISI 304)	233	Plate	EN 1.4301 (AISI 304)

[1]= Single phase only

[2]= MATRIX 18-5T/4 and MATRIX 18-6T/4 only

### MECHANICAL SEAL standard

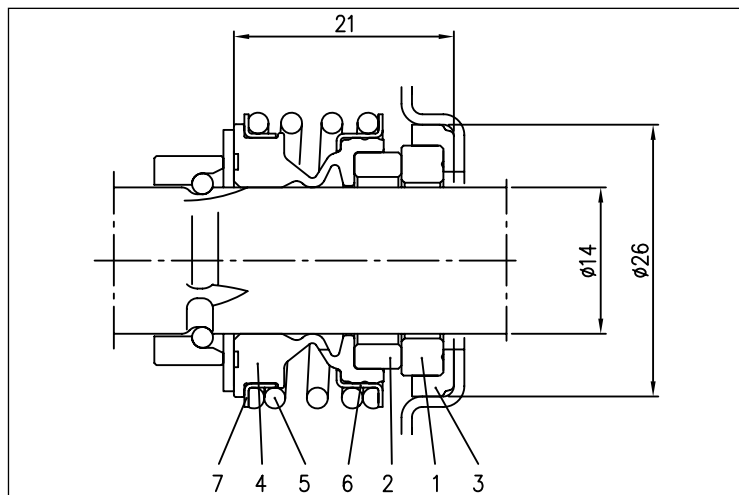

### MATERIALS TABLE standard

Ref.	Name	Materials
1	Fixed part	Ceramic
2	Rotating part	Carbon
3	Gasket	EPDM
4	Diaphragm	EPDM
5	Spring	EN 1.4402 (AISI 316)
6	Structure/frame	EN 1.4402 (AISI 316)
7	Retainer ring	EN 1.4402 (AISI 316)

### SPECIAL MECHANICAL SEALS (on request)

Ref.	Name	Materials			
		H Version	HS Version	U3Q1EGG Version	Q1AEGG Version
1	Fixed part	Carbon	Silicon Carbide	Tungsten Carbide	Silicon Carbide
2	Rotating part	Ceramic	Silicon Carbide	Silicon Carbide	Metallised carbon
3	Gasket	FKM	FKM	EPDM	EPDM
4	Diaphragm	FKM	FKM	EPDM	EPDM
5	Spring	EN 1.4402 (AISI 316)	EN 1.4402 (AISI 316)	EN 1.4402 (AISI 316)	EN 1.4402 (AISI 316)
6	Structure/frame	EN 1.4402 (AISI 316)	EN 1.4402 (AISI 316)	EN 1.4402 (AISI 316)	EN 1.4402 (AISI 316)
7	Retainer ring	EN 1.4402 (AISI 316)	EN 1.4402 (AISI 316)	EN 1.4402 (AISI 316)	EN 1.4402 (AISI 316)

# MATRIX

## HORIZONTAL MULTISTAGE CENTRIFUGAL ELECTRIC PUMPS

in AISI 304

### MECHANICAL SEAL HIGH TEMPERATURE

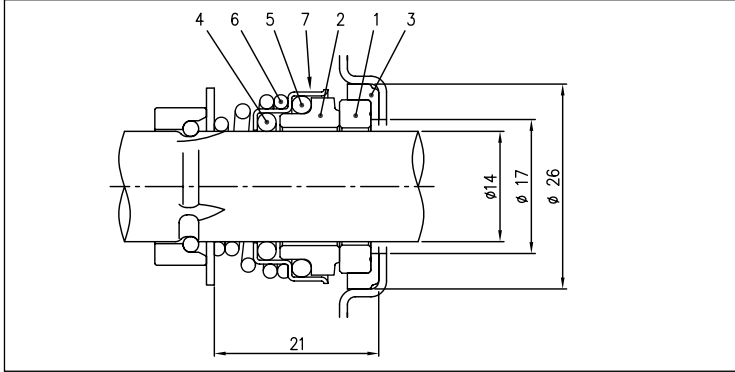

### MATERIALS TABLE HIGH TEMPERATURE

Ref.	Name	Material
1	Stationary seal ring	Ceramic
2	Rotary seal ring	Carbon
3	Gasket	EPDM
4	O-Ring	EPDM
5	O-Ring	EPDM
6	Spring	EN 1.4402 (AISI 316)
7	Retainer ring	EN 1.4301 (AISI 304)

### ELECTRIC DATA TABLE

Model	Single phase 230V	Three phase 230/400V	P <sub>2</sub>		Efficiency		Capacitor		Efficiency			P <sub>1</sub>		Absorbed Current				
			[HP]	[kW]	Single phase	Three phase	Single phase	Three phase	η %	50%	75%	100%	Single phase	Three phase	Single phase	Three phase	Three phase	
							μF	V <sub>e</sub>										
MATRIX 3-2T/0.45M	MATRIX 3-2T/0.45	MATRIX 3-2T/0.45	0,6	0,45	-	-	12,5	450	-	-	-	0,73	0,72	3,2	2,3	1,3		
MATRIX 3-3T/0.65M	MATRIX 3-3T/0.65	MATRIX 3-3T/0.65	0,9	0,65	-	-	16	450	-	-	-	0,97	0,85	4,5	2,8	1,6		
MATRIX 3-4T/0.65M	MATRIX 3-4T/0.65	MATRIX 3-4T/0.65	0,9	0,65	-	-	16	450	-	-	-	0,97	0,85	4,5	2,8	1,6		
MATRIX 3-5T/0.75M	MATRIX 3-5T/0.75	MATRIX 3-5T/0.75	1,0	0,75	-	IE3	25	450	80,9	82,3	82,1	1,14	0,91	5,4	3,0	1,7		
MATRIX 3-6T/0.9M	MATRIX 3-6T/0.9	MATRIX 3-6T/0.9	1,2	0,9	-	IE3	31,5	450	81,7	83,1	82,4	1,28	1,34	5,7	4,3	2,5		
MATRIX 3-7T/1.3M	MATRIX 3-7T/1.3	MATRIX 3-7T/1.3	1,8	1,3	-	IE3	35	450	83,0	85,8	85,6	1,75	1,77	7,8	5,8	3,3		
MATRIX 3-8T/1.3M	MATRIX 3-8T/1.3	MATRIX 3-8T/1.3	1,8	1,3	-	IE3	35	450	83,0	85,8	85,6	1,75	1,77	7,8	5,8	3,3		
MATRIX 3-9T/1.5M	MATRIX 3-9T/1.5	MATRIX 3-9T/1.5	2,0	1,5	-	IE3	40	450	82,7	86,1	87,0	1,95	1,72	8,7	6,6	3,8		
MATRIX 5-2T/0.45M	MATRIX 5-2T/0.45	MATRIX 5-2T/0.45	0,6	0,45	-	-	12,5	450	-	-	-	0,73	0,72	3,2	2,3	1,3		
MATRIX 5-3T/0.65M	MATRIX 5-3T/0.65	MATRIX 5-3T/0.65	0,9	0,65	-	-	16	450	-	-	-	0,97	0,85	4,5	2,8	1,6		
MATRIX 5-4T/0.9M	MATRIX 5-4T/0.9	MATRIX 5-4T/0.9	1,2	0,9	-	IE3	31,5	450	81,7	83,1	82,4	1,28	1,34	5,7	4,3	2,5		
MATRIX 5-5T/1.3M	MATRIX 5-5T/1.3	MATRIX 5-5T/1.3	1,8	1,3	-	IE3	35	450	83,0	85,8	85,6	1,75	1,77	7,8	5,8	3,3		
MATRIX 5-6T/1.3M	MATRIX 5-6T/1.3	MATRIX 5-6T/1.3	1,8	1,3	-	IE3	35	450	83,0	85,8	85,6	1,75	1,77	7,8	5,8	3,3		
MATRIX 5-7T/1.5M	MATRIX 5-7T/1.5	MATRIX 5-7T/1.5	2,0	1,5	-	IE3	40	450	82,7	86,1	87,0	1,95	1,72	8,7	6,6	3,8		
MATRIX 5-8T/2.2M	MATRIX 5-8T/2.2	MATRIX 5-8T/2.2	3,0	2,2	-	IE3	50	450	86,2	87,0	86,0	2,92	2,55	13,0	8,2	4,7		
MATRIX 5-9T/2.2M	MATRIX 5-9T/2.2	MATRIX 5-9T/2.2	3,0	2,2	-	IE3	50	450	86,2	87,0	86,0	2,92	2,55	13,0	8,2	4,7		
MATRIX 10-2T/0.75M	MATRIX 10-2T/0.75	MATRIX 10-2T/0.75	1,0	0,75	-	IE3	25	450	80,9	82,3	82,1	1,14	0,91	5,4	3,0	1,7		
MATRIX 10-3T/1.3M	MATRIX 10-3T/1.3	MATRIX 10-3T/1.3	1,8	1,3	-	IE3	35	450	83,0	85,8	85,6	1,75	1,77	7,8	5,8	3,3		
MATRIX 10-4T/1.5M	MATRIX 10-4T/1.5	MATRIX 10-4T/1.5	2,0	1,5	-	IE3	40	450	82,7	86,1	87,0	1,95	1,72	8,7	6,6	3,8		
MATRIX 10-5T/2.2M	MATRIX 10-5T/2.2	MATRIX 10-5T/2.2	3,0	2,2	-	IE3	50	450	86,2	87,0	86,0	2,92	2,55	13,0	8,2	4,7		
MATRIX 10-6T/2.2M	MATRIX 10-6T/2.2	MATRIX 10-6T/2.2	3,0	2,2	-	IE3	50	450	86,2	87,0	86,0	2,92	2,55	13,0	8,2	4,7		
MATRIX 18-2T/1.5M	MATRIX 18-2T/1.5	MATRIX 18-2T/1.5	2,0	1,5	-	IE3	40	450	82,7	86,1	87,0	1,95	1,72	8,7	6,6	3,8		
MATRIX 18-3T/2.2M	MATRIX 18-3T/2.2	MATRIX 18-3T/2.2	3,0	2,2	-	IE3	50	450	86,2	87,0	86,0	2,92	2,55	13,0	8,2	4,7		
-	MATRIX 18-4T/3	MATRIX 18-4T/3	4,0	3	-	IE3	-	-	85,9	87,5	87,1	-	3,44	-	11,1	6,4		
-	MATRIX 18-5T/4	MATRIX 18-5T/4	5,5	4	-	IE3	-	-	85,8	88,3	88,4	-	4,52	-	15,1	8,7		
-	MATRIX 18-6T/4	MATRIX 18-6T/4	5,5	4	-	IE3	-	-	85,8	88,3	88,4	-	4,52	-	15,1	8,7		

The content of this publication should not be considered mandatory. EBARA Pumps Europe S.p.A. reserves the right to change the content without prior notice.



# MATRIX

## HORIZONTAL MULTISTAGE CENTRIFUGAL ELECTRIC PUMPS

in AISI 304

### NOISE DATA TABLE

Model		P <sub>2</sub>		L <sub>PA</sub> - dB(A)*
Single phase 230V	Three phase 230/400V	[HP]	[kW]	
MATRIX 3-2T/0.45M	MATRIX 3-2T/0.45	0.6	0.45	61
MATRIX 3-3T/0.65M	MATRIX 3-3T/0.65	0.9	0.65	
MATRIX 3-4T/0.65M	MATRIX 3-4T/0.65	0.9	0.65	62
MATRIX 3-5T/0.75M	MATRIX 3-5T/0.75	1.0	0.75	
MATRIX 3-6T/0.9M	MATRIX 3-6T/0.9	1.2	0.9	64
MATRIX 3-7T/1.3M	MATRIX 3-7T/1.3	1.8	1.3	
MATRIX 3-8T/1.3M	MATRIX 3-8T/1.3	1.8	1.3	64
MATRIX 3-9T/1.5M	MATRIX 3-9T/1.5	2.0	1.5	
MATRIX 5-2T/0.45M	MATRIX 5-2T/0.45	0.6	0.45	61
MATRIX 5-3T/0.65M	MATRIX 5-3T/0.65	0.9	0.65	
MATRIX 5-4T/0.9 M	MATRIX 5-4T/0.9	1.2	0.9	62
MATRIX 5-5T/1.3M	MATRIX 5-5T/1.3	1.8	1.3	
MATRIX 5-6T/1.3M	MATRIX 5-6T/1.3	1.8	1.3	64
MATRIX 5-7T/1.5 M	MATRIX 5-7T/1.5	2.0	1.5	
MATRIX 5-8T/2.2 M	MATRIX 5-8T/2.2	3.0	2.2	65
MATRIX 5-9T/2.2 M	MATRIX 5-9T/2.2	3.0	2.2	
MATRIX 10-2T/0.75M	MATRIX 10-2T/0.75	1.0	0.75	62
MATRIX 10-3T/1.3M	MATRIX 10-3T/1.3	1.8	1.3	
MATRIX 10-4T/1.5M	MATRIX 10-4T/1.5	2.0	1.5	64
MATRIX 10-5T/2.2M	MATRIX 10-5T/2.2	3.0	2.2	
MATRIX 10-6T/2.2M	MATRIX 10-6T/2.2	3.0	2.2	65
MATRIX 18-2T/1.5M	MATRIX 18-2T/1.5	2.0	1.5	
MATRIX 18-3T/2.2M	MATRIX 18-3T/2.2	3.0	2.2	65
-	MATRIX 18-4T/3	4.0	3	
-	MATRIX 18-5T/4	5.5	4	68
-	MATRIX 18-6T/4	5.5	4	

\* Mean value of several measurements at 1 m distance around the pump.  
Tolerance ± 2.5 dB.

Insulation casing



For applications with refrigerant liquids or liquids with high thermal difference that may generate condensate